

CAPACITY	SYMBOL/ SERIAL NO.	CIRCUIT DIAGRAM
AC 250V		
16A		

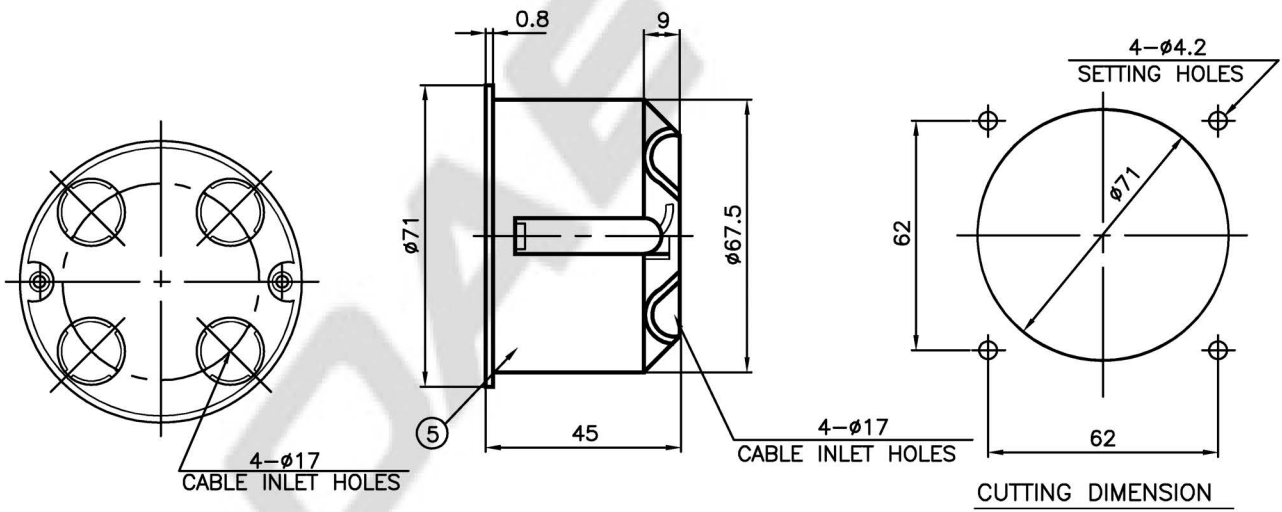
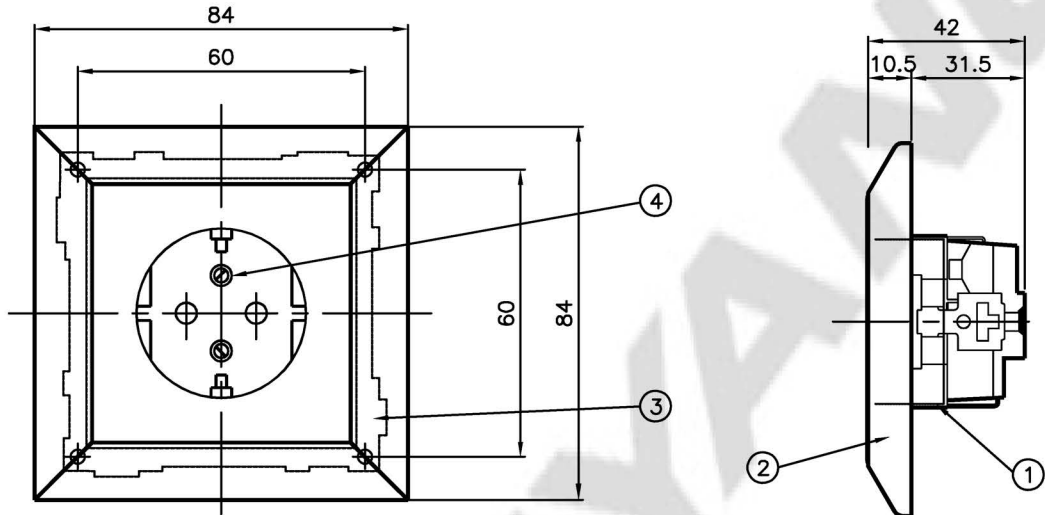

5	MOUNTING BOX	ABS	1		3	MOUNTING PLATE	STEEL	1	
4	SCREW	STEEL	1		2	COVER	ABS	1	
					1	INTERIOR BODY	PHENOL	1	
NO	NAME OF PARTS	MATERIAL	Q'TY	REMARKS	NO	NAME OF PARTS	MATERIAL	Q'TY	REMARKS

APPROVED	O. J. KWON	UNIT	MM
CHECKED		SCALE	N/S
DRAWING	B. I. KIM	COLOR	POLAR WHITE
DATE	2019.03.03	IP	20

TITLE;
**NON WATERTIGHT
 SINGLE RECEPTACLE(FLUSH)
 2P+1E (DIN TYPE)
 FOR MARINE USE**

DAEYANG	MODEL NO.	S-1014PT	WEIGHT	0.1 Kg
	DWG NO.	L62320001	SHEET NO.	12